

Tormach Series 3 CNC Mills

Design Analysis Whitepaper

Contents

Introduction.....	1
Motion System Design Theory.....	2
Speed Failure Analysis	2
Reserve Force Analysis	4
Application of Reserve Force Analysis on the Series 3 PCNC 1100	6
Stepper Motion Technology	7
Overview of the Technology.....	7
Stepper Motors.....	7
Stepper Drivers	8
Tormach Evaluations	13
Test regimen	13
Test Results.....	14
Difficult Decisions	20
Summary.....	21

Introduction

“Best is the enemy of good.” (Voltaire). Voltaire’s idea could be the analog to the more common idiom: "If it ain't broke, don't fix it.". Any way you look at it, the concept has a lot to do with the development of Tormach’s Series 3 mills. What started as a simple engineering test of some interesting motor technology evolved into an 8 month investigation and resulted in an entirely new generation of machines. Despite the fact that our machine designs have seen years of successful operation, with few maintenance or reliability issues, as engineers we couldn’t leave it alone. Seeing the performance advancement that was possible, we felt we had to make the change.

The core of the change was a conversion from the more common bipolar stepper motor/drive technology to 3 phase motor/drive technology. The new technology shows dramatic improvements in linearity, and noise, with reduced susceptibility to resonance. The result of the design change is a mix of smoother and more accurate operation. The



Enabling Your Ideas

Technical Document

PCNC 1100 offers higher speeds, and both PCNC 1100 and 770 models have significant increases in reserve torque capacity. Additional benefits include reduced motor temperature, drive over temperature protection, reverse power protection, and short circuit protection. These major changes are complemented with a variety of small detail changes like improved paint, simplified wiring, and an X axis motor protection shelf. This paper has two major sections, a design theory chapter that describes how we approached the design decisions, and a summary of the motor/drive testing which provided the raw data we used as input to our design approach.

Motion System Design Theory

Motion system design in fixed applications like packaging machines, printers, or similar machinery, involves detailed analysis of machine dynamics with full consideration of friction, loads, and more. Motion system design for CNC machinery is far different because the masses and application loads are highly variable; depending very much on how any particular machinist decides to use the machine. When designing CNC machinery we perform a conventional dynamics analysis, but in addition we like to employ a design approach we call *Reserve Torque Analysis*. The method is simple but rarely used because it requires a full knowledge of a force/speed curve.

The value of *Reserve Torque Analysis* can best be understood when compared to the more common design method typically used by designers of low cost machinery. For lack of a better term, we'll call it a *Speed Failure Analysis*. With *Speed Failure Analysis* the design approach is simple: The machine is tested to find the speed at which the machine faults, and then the design speed is set to some slightly lower speed to avoid faulting. If the machine faults frequently in use, the recommendation is to pull the speed limit back even further.

Speed Failure Analysis

The frequent use of a *Speed Failure Analysis* is largely responsible for the bad reputation commonly attributed to stepper systems. This can easily be understood by looking at some typical speed/force curves. The graph below shows a typical force curve for a stepper and a servo system. The available force of a stepper (green line) is enormous at slow speeds, then drops off rapidly, but flattens out to a low force level at higher speeds. In contrast, a servo system (blue line) has a very flat line for available force until it reaches a speed known as the back EMF¹ limit. This speed is typically higher than can be achieved with a stepper system.

¹ EMF stands for Electromotive Force. This is the point where the self-generated voltage of the motor begins to meet the DC level of the drive bus, thus losing its capacity to take current.

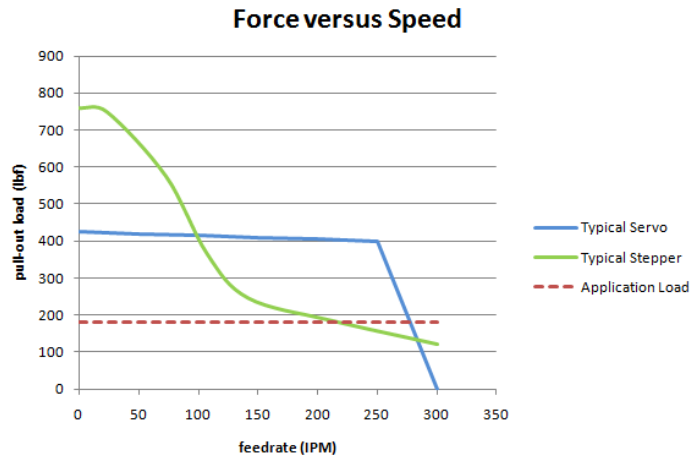

Now consider the servo system designer who, during test observes failures at about 280 inches per minute. This is the point where the servo force (blue line) falls below the force needed by the application (dotted red line). As an example in the chart, we’re assuming an application load of around 180 lbs of force. Using a *Speed Failure Analysis*, the designer might guess that 15% reduction in maximum speed would be safe, thus setting the machine speed limit to around 240 inches per minute. Looking back at the graph, we can see that due to the sharp decline in servo torque, a mere 15% reduction in machine speed has created a significant margin in available force.

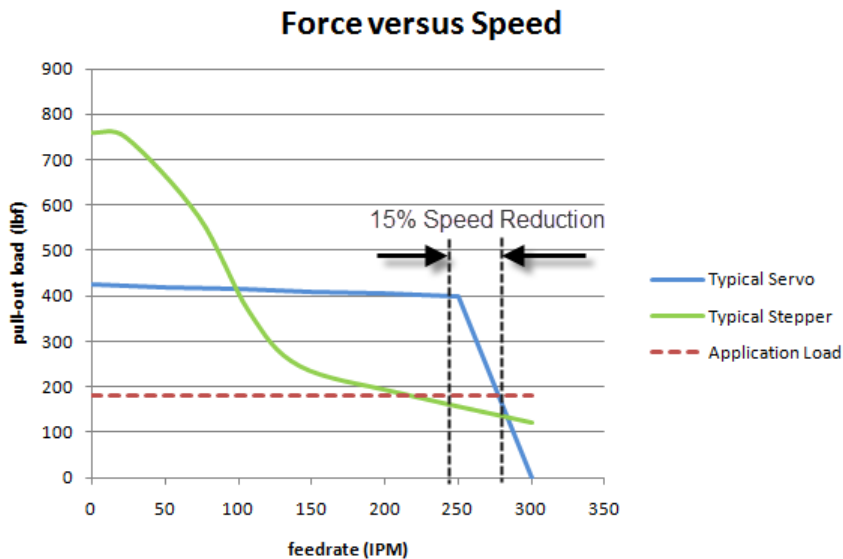

Now consider the same analysis approach on a stepper system. The system can be observed to fail under load at around 220 inches per minute. A 15% reduction in maximum speed sets the maximum design speed to 187 inches per minute. In this case, because we’re into the slow decline area of the stepper force level, the force margin is minimal and the system remains at risk of failure.

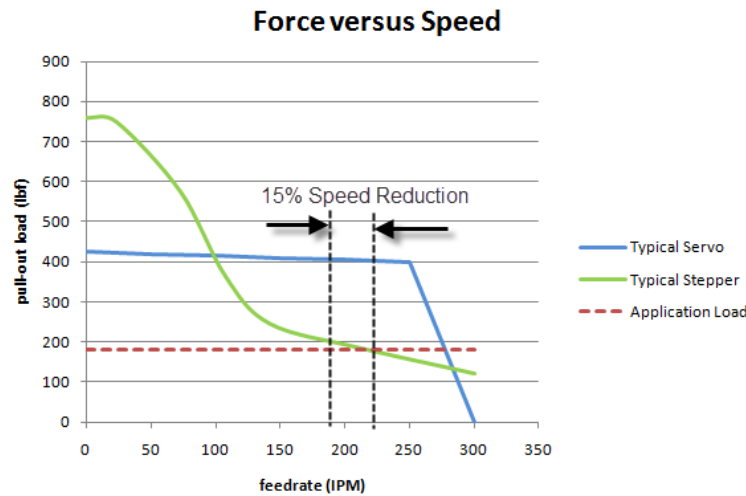

The net result is that, when using the same design rule, the resulting stepper system is more prone to failure as compared to a servo system. Looking at the available force at slower speeds, it is clear that the stepper system has plenty of force at lower speeds. The fault is not with stepper systems in general, but rather with the design methodology. A *Speed Failure Analysis* is simply not a good design method when designing with stepper systems.

A better method is *Reserve Force Analysis*; unfortunately it requires a full detailed knowledge of the speed/force profile, which is difficult to obtain. When working with stepper motors and drivers there are complex interactions between motor induction, resistance, inertia, and the electrical characteristics of the stepper drivers. While motor manufacturers frequently publish speed/torque curves for their motors, the speed torque curves are idealized under test conditions using a driver selected by the manufacturer. Results are NOT the same when the motors are used in application, with different mechanics and drivers. The only truly accurate data is that which is recorded in application, using a machine dynamometer in combination with the actual machine. This is the approach Tormach uses for collecting data to be used in a *Reserve Force Analysis*.

Reserve Force Analysis

With *Reserve Force Analysis* the maximum allowed machine speed is determined so it will maintain a specific level of reserve force, above and beyond the expected application load. In the examples below we show a system with an approximate 180 lbs of application load and a 200 lb reserve. On the left graph the servo system design results in 255 IPM limit while the stepper system on the right has a 105 IPM limit. These are the points where the available axis force intersects the black line, the reserve+application load level. The blue line (servo) intersects at 255, while the green line (stepper) intersects at 105.

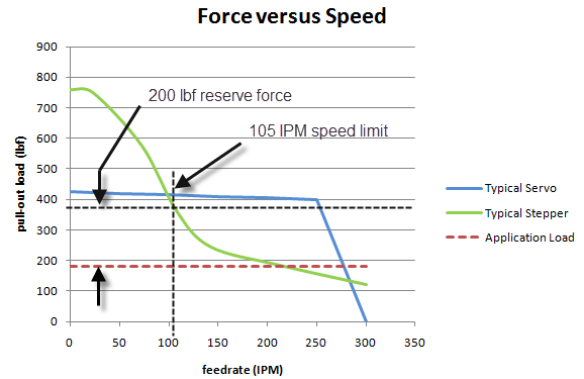
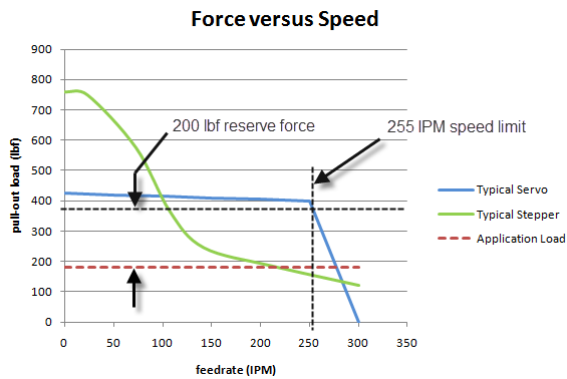

It should be apparent that this design method is not only more conservative, but it yields a design where the stepper driven system has no more risk of motion faults than the servo system. In fact the stepper system excels in all aspects except speed. Consider the case shown below, where the machine is running at 50 IPM. This is a typical speed for heavy cutting involving large forces. Whereas our design reserve is 200 lbs, the stepper system available reserve force is 500 lbs in the stepper system while the servo system is only 240 lbs, less than half of the overload reserve capacity.

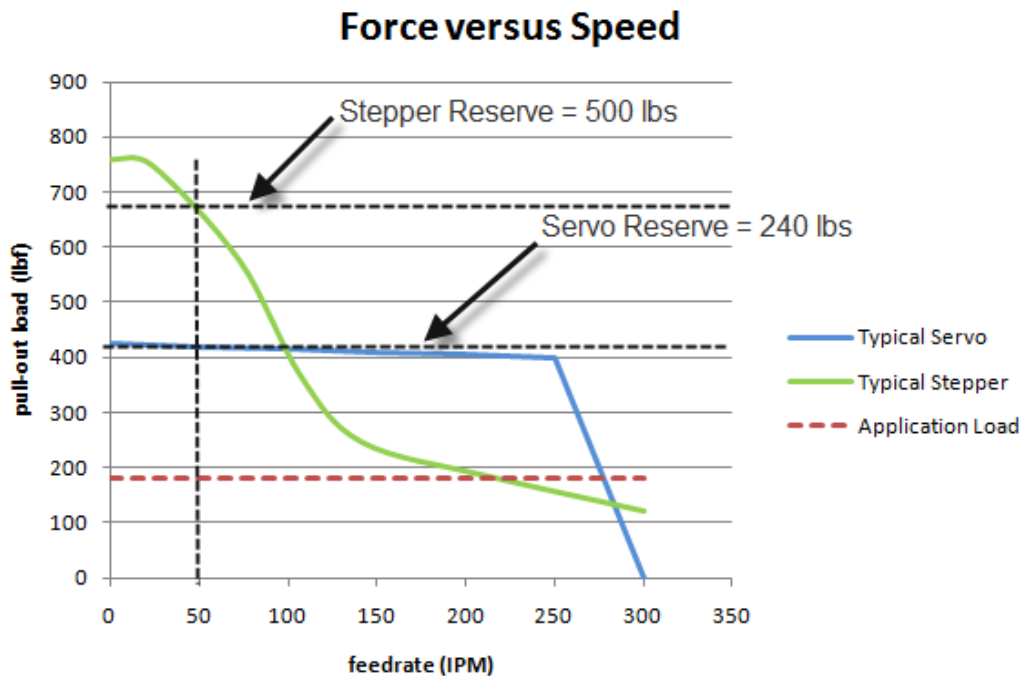

When performing this sort of analysis it is important to use the continuous force/torque rating of a motor, not the peak rating. CNC machinery is subject to long runs and experienced machinists regularly tweak their CNC codes to push the machine continuously to the limit. Use of peak motor rating in a servo system is acceptable only if occasional errors in machining are allowable.

Application of Reserve Force Analysis on the Series 3 PCNC Mills

The previous plots used typical stepper and servo profiles. The design summary and analysis plots that follow utilize the on-machine data collected at Tormach in our recent motor/driver evaluations. The first chart below compares the X and Y axis drive systems in the earlier Series 2 PCNC 1100 to the new X and Y drive system we selected for Series 3 PCNC 1100 mills. The 3 phase motor drive combination we found offers so much performance improvement that we decided to simultaneously increase both our reserve force level and the machine speed. The Series 2 design assumed a basic load level of 200 lbs and a safety reserve force level of 375 lbs. This resulted in a machine speed limit of 90 IPM.

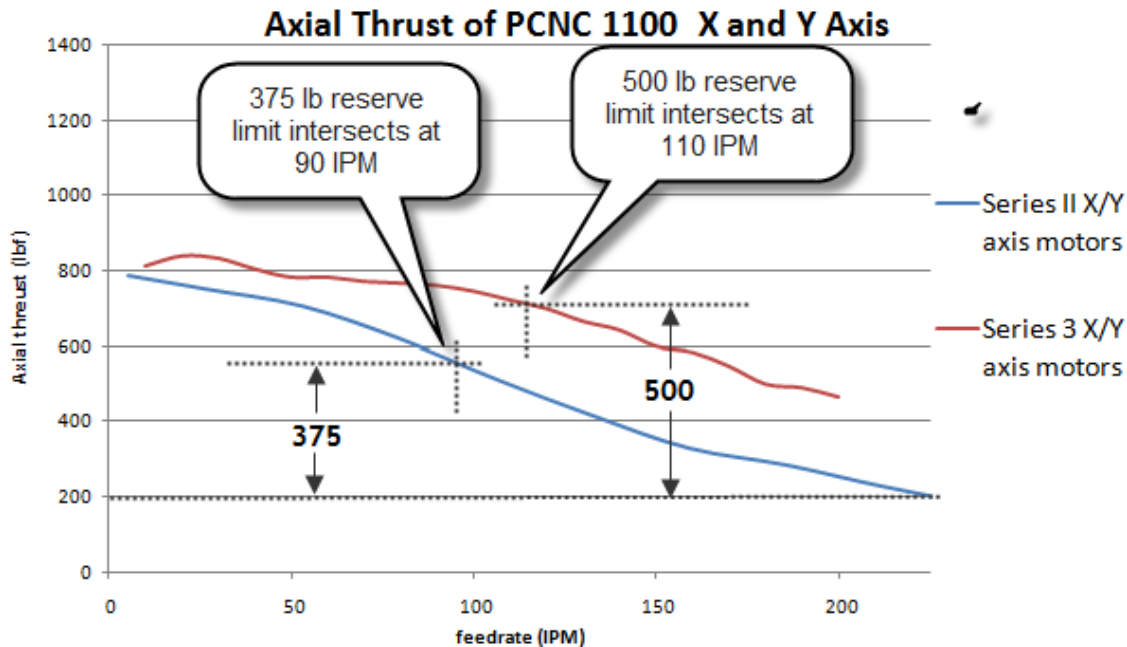

With the Series 3, the safety reserve limit has been increased to 500 lbs, yet the improved performance of the new motor/drive combination results in a machine speed increase to 110 IPM.²

The Z axis has a similar story. We assumed a 300 lb application load on Z because of the potential for a large downward force when drilling. Using a 450 lb safety reserve in Series 2 allowed 65 IPM on the axis. Increasing the safety reserve to 550 lbs on Series 3 allowed an axis speed increase to 90 IPM. As with the X and Y axis, the Series 3 evolution provides both increased speed and an increase in reserve cutting force for overload situations without risk of motion faults. The Z axis change does offer reduced available force at slow speed, but remains far more that is ever needed in applications and overload situations.

² The curious observer might wonder why we didn't stay with 375 lbs reserve and increase the machine speed even further. The answer is that higher speeds, in the vicinity of 130 to 150 IPM, approach mid-band resonance frequency. Mid-band resonance is a subject beyond the scope of this paper.

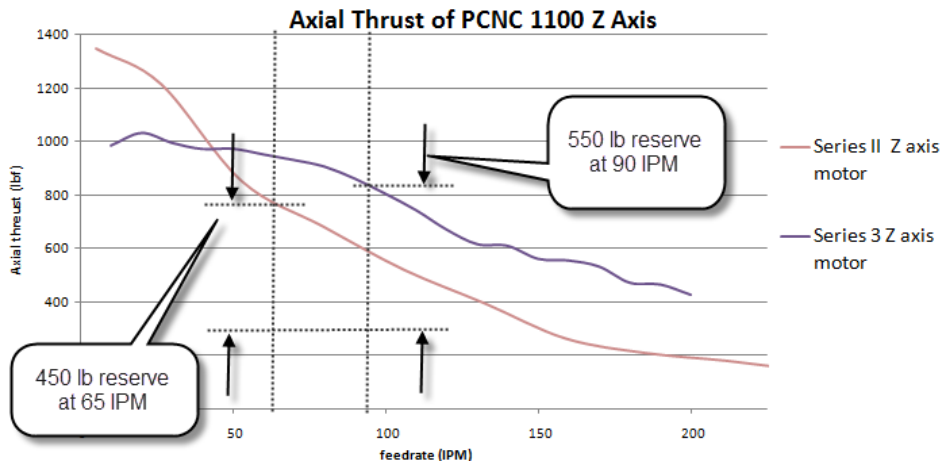

The PCNC 770 reserve force graphs are not shown for the sake of brevity, but the results are changes in reserve force only, the axis speeds have remained the same. The X and Y axis has seen an increase in reserve axial force of 175 lbs, from 225 lbf to 400 lbf. The Z axis has seen an increase in reserve force of 200 lbf, from 350 on the original PCNC 770 to 550 on the new Series 3 PCNC 770

Stepper Motion Technology

Overview of the Technology

Stepper motors are in use in a broad spectrum of motion control applications – annual stepper sales worldwide approach one billion US dollars - and the technology in stepper drivers has advanced significantly in the last decade. Because of these technological advances we felt we might be able to improve upon our original motor/drive selection. In the spring of 2010 we embarked on what turned into an 8 month-long analysis of currently available stepper motors and drives in an attempt to improve the performance and value of our product line. The result was a massive project that absorbed two full-time engineers for a matter of months. In all, we evaluated 21 drivers and almost 30 motors from a range of manufacturers. The various combinations of motor and driver resulted in over 1,000 unique tests and roughly one million data points collected.

What follows is an overview of the operating theory behind stepping motors and drivers, a description of our testing regimen, a presentation of a subset of the test data, and a summary of the results.

Stepper Motors

The PCNC 1100 and 770 mills use stepper motors to drive X, Y, Z, and A axes. Stepper motors have the advantage of being more reliable, less sensitive to electrical noise, and considerably less expensive than the alternative, the AC brushless servo motor, while maintaining comparable

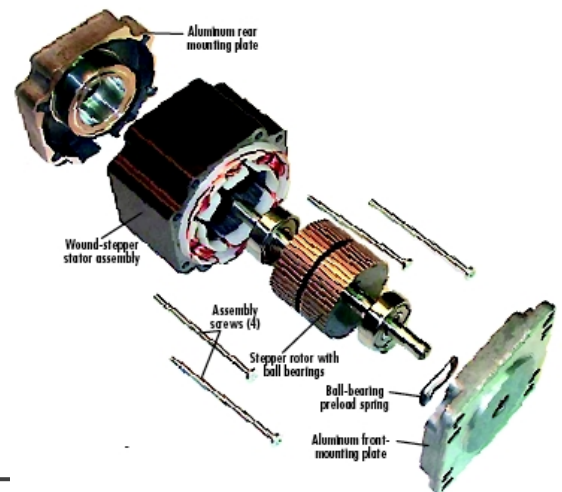



Enabling Your Ideas

Technical Document

positional accuracy. Stepper motors are typically operated in open-loop systems, meaning that the drive sends a position and direction signal, but does not require positional feedback from an encoder. This reduces system complexity, number of failure modes, and cost. While closed loop control of stepper motors is possible, it should be realized that the choice of open or closed loop control has no impact on the torque-producing capabilities of the motor. A condition that may stall an open loop stepper system (mechanical binding, machine crash) will also stall a closed loop servo system.

There are a wide variety of stepper motor types currently manufactured (single stack, multi-stack, variable reluctance, hybrid) but for precise motion control the industry standard is the hybrid stepper motor. These motors are able to provide very high torque at low speeds, with positional accuracy typically approaching 1/5 of a degree, translating into about one ten-thousandth of an inch of travel on a 5 turn-per-inch ballscrew.

In hybrid stepper motors motion is achieved through the interaction of a magnetic field created by current in the stator winding and the permanent magnet on the rotor. Both the stator poles and the rotor are toothed, typically resulting in a motor with 200 'full' steps per revolution. Advanced drives allow microstepping, a practice by which the current in the stator coils is adjusted to achieve positions between full steps, yielding greatly improved positional accuracy and smoothness of motion.

Alternating currents in the coils of the stepper motor's stator result in shaft rotation whose velocity is proportional to the frequency of the alternating current. At high step rates the ability of the stepper driver to deliver its rated current is impeded by the inductance of the windings and the back EMF of the motor. Practically speaking, this means that at higher velocities the motor will provide less torque. The high speed performance of a stepper can be extended by increasing the bus voltage of the driver to a point - drivers that will accept voltages higher than 80V are rare.

Hybrid stepper motors are manufactured with different numbers of phases in the stator. Most common are two and three phase motors, but five phase and other polyphase motor configurations exist. Two phase motors dominate the US market; three phase motors are more popular overseas. Three phase motors, while slightly more expensive, have the advantages of inherently higher positional accuracy and smoother motion because of the added phase. The number of phases in a stepper motor should not be confused with the power requirements of the motor; while a three phase induction motor will operate only on three phase alternating current, stepper motor drivers almost universally require a regulated DC supply.

Stepper Drivers

For a given type of stepper motor, performance is strongly dependent on the motor driver. In our testing we noted significant differences in torque, positional accuracy, heating, vibration, and susceptibility to resonance between drivers using an identical motor. In contrast, the motors we tested tended to differ mainly in terms of their mass moment, induction, resistance, and torque/current ratio. Based on performance criteria alone, the stepper driver may be the most critical component in the motion control equation. During testing we consistently confirmed the fact that published motor speed/torque curves cannot be used to predict system performance. The only real performance test is an on-machine test using an integrated machine dynamometer.

Reliability is another important factor in driver selection. In our nearly 10 years of machine manufacturing, we have seen stepper motors fail only on a handful of occasions. Drivers, like many electronic components, are more susceptible to the perils of a metalworking environment (coolant, chips, humidity, vibration, heat) than stepper motors. They are also usually 2 to 3 times more expensive to replace than motors when they fail. As such, it was important to us to evaluate the amount of abuse that a stepper driver could take before failing.

Stepper drivers take step and direction signals (0 to 5 volt pulses) from the control computer and translate them into current levels in the windings of the stepper motor. The simplest implementation of such a driver is a circuit employing an H-bridge to turn current in a winding on or off:

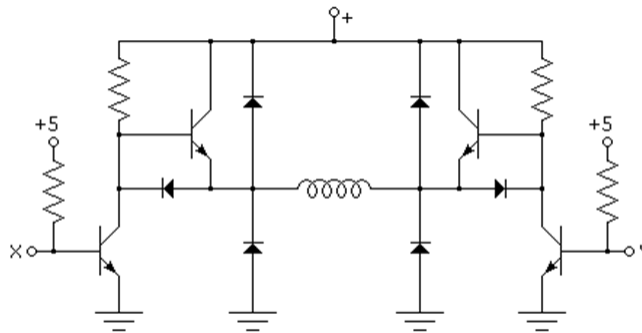

Figure 2

A differential signal at the X and Y terminals allows current to flow through one of the motor’s windings. Changing the polarity of the differential signal changes the direction of the current. This simple circuit would drive a stepper motor in full step mode – current in the motor winding is either “full on” in one direction or the other.

Most drives manufactured within the last ten years have the ability to control the current levels in the motor windings at increments finer than simply “on” or “off”. The ability to adjust the winding current levels allows the drive to stop the motor at positions in between the 200 “natural” or “full” motor step positions. This technology is known as microstepping. Figure three shows an oscilloscope trace of the current in one phase of a bipolar hybrid stepper motor being driven at a 10 microstep resolution. The discrete current levels between 0 current and full current appear as stair steps superimposed on the sinusoid:

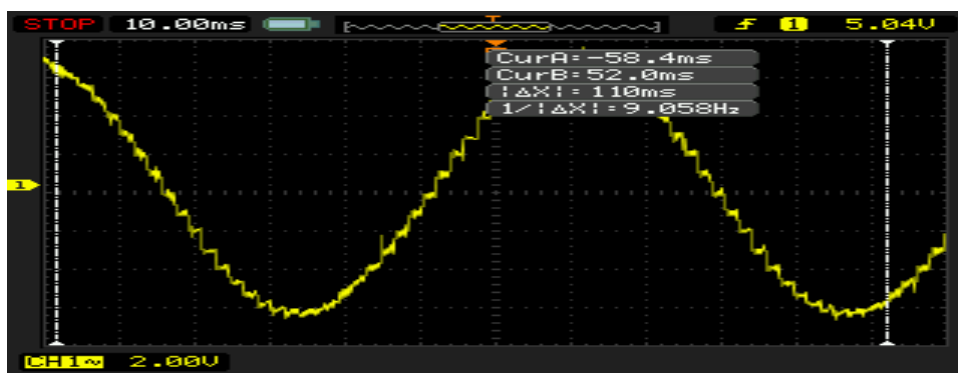

Figure 3.

Because the accuracy of most stepping motors diminishes beyond about 1/5 of a degree (about 1/10th of a step), many microstepping drivers are designed with resolutions of 10 microsteps per step. Depending on the motor, microstep resolutions beyond 10 may not increase the positional accuracy of the motor/drive combination, but higher microstep resolution can reduce noise and vibration in the motor. Be aware that higher microstep resolutions are harder to support from the control computer's standpoint. A 100 inch/minute feed rate on the PCNC 1100 translates into a step pulse stream of 16,700 Hz. Increasing the microstep resolution from 10 to 20 doubles the frequency of the pulse stream (33,000 Hz) needed to drive the mill at 100 IPM. The practical limit for pulse frequency is dependent on the computer, but frequencies above 30,000 Hz are hard for most personal computers to reliably deliver.

Driver Linearity

In an ideal motor, sinusoidal currents of opposite polarity in the two phases of a bipolar hybrid stepper motor would result in rotary motion proportional to the changing current. In real life, position deviates from the expected position by a small amount, as shown on this graph of commanded versus actual position (values from PCNC 1100 Series II X axis motor/drive):

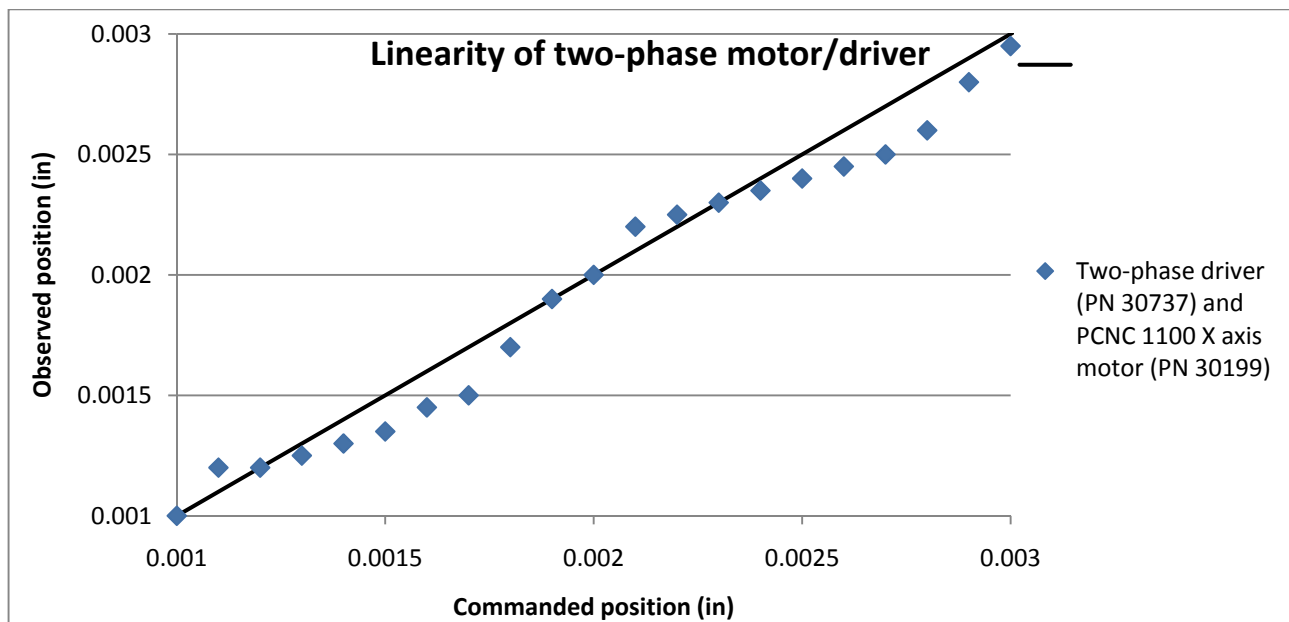

Figure 4

Note the superposition of a sinusoid over the straight line. This deviation between commanded and actual position shows the non-linearity of the motor/drive combination. Sophisticated drivers attempt to reduce non-linearity by altering the shape of the current waveform. Others provide an offset adjustment via a trim pot on the drive to reduce non-linearity. Because of the presence and spatial orientation of the third phase, three phase stepper motors inherently exhibit better linearity than two phase motors. The sinusoidal variation is a pattern that repeats every 4 full steps. Three phase motors are also advantaged by the fact that the native full steps are 300 steps per revolution as

opposed to the 200 steps per revolution in most bipolar motors. This increased step count yields finer granularity to any linearity errors.

Noise and Vibration

Noise and vibration in stepping motor systems stem from two causes. At very slow step rates (feed rates under 1 inch per minute) the stream of discrete pulses results in motor vibration because the rotor motion at these low speeds is not continuous. At higher step rates vibration is mainly a result of resonance. A stepper motor's energized stator and rotor can be thought of as a mass-spring system. Like any mass-spring system, stepper motors have natural resonant frequencies. The maximum motor vibration occurs when the commanded step rate matches the natural resonant frequency of the motor. This frequency is dependent on motor design, but during our testing we found that two phase motors resonate at around 50 RPM (corresponding to a feed rate of 10 IPM on the PCNC 1100) and three phase motors resonate at around 125 RPM (25 IPM). The magnitude of the vibration is strongly dependant on three things:

1. Motor configuration - three phase motors tend to vibrate less than two phase.
2. Motor current setting - higher motor currents lead to more vibration and noise.
3. Drive design – some drives are better at damping resonance than others

The higher vibration peak due to resonance on a two phase stepper is clearly visible in Figure 5:

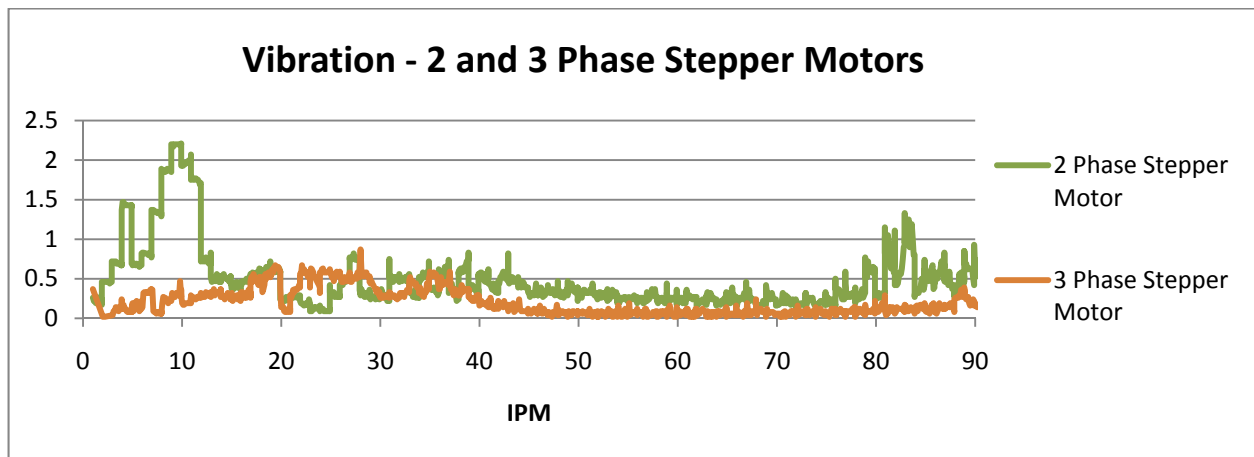

Figure 5

High speed performance

As previously discussed, stepper motors' high speed performance is limited by the coil inductance and bus voltage. At higher speeds the current in the motor coils must alternate more frequently. You may recall that impedance increases linearly with frequency ($Impedance = 2\pi fL$). At some point, typically in the range of 400-700 RPM, the drive is no longer able to force the rated current through the motor coils, and torque starts to drop off. The drop in current is accompanied by a drop in torque, and is visible as a "knee" on a speed-torque curve:

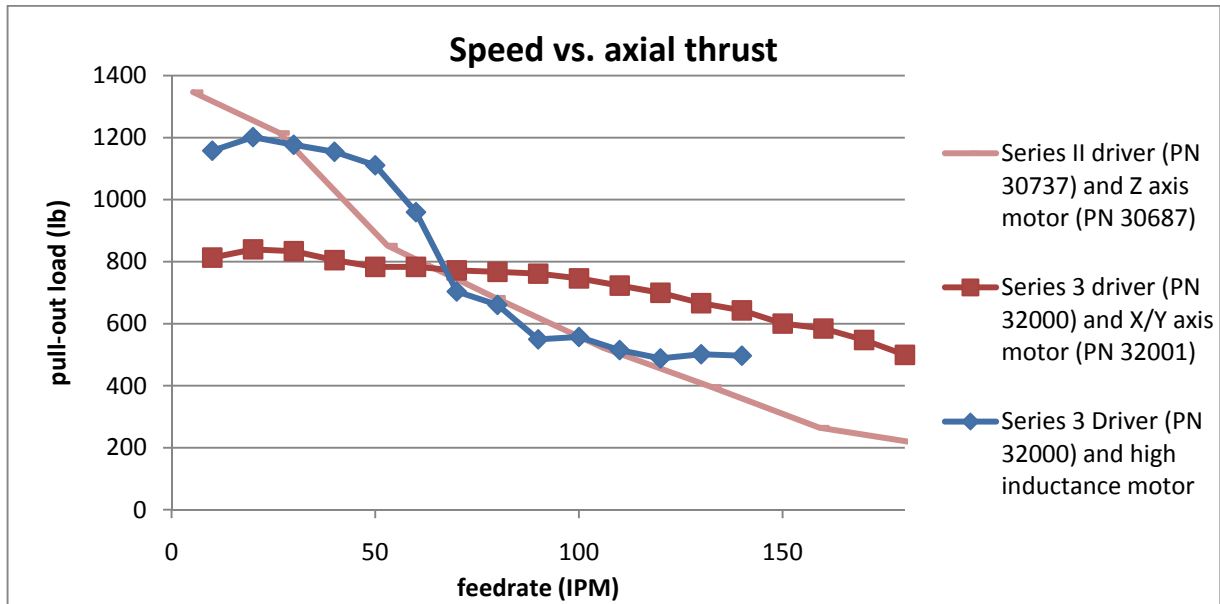

Figure 6

The speed at which the drive becomes current-limited by inductance is determined by (in order of importance):

1. The motor’s inductance (related to number of windings in the stator and the wire size used)
2. The drive’s supply voltage (most drives are limited to ~70VDC)
3. The drive’s ability to source current (dependant on drive design)

The dotted red line shown in Figure 6 corresponds to a motor with low inductance, and therefore very good high speed performance. The tradeoff, which is apparent on this chart, is that to get high speed performance you must sacrifice low speed torque. The motor that we have used for the Z axis on the PCNC 1100 Original and Series II delivered nearly 1400 lbs of linear force to the Z axis at low speeds. At the rapid traverse rates of 65 IPM that same motor barely transmits 800 lbs of force to the Z axis.

This exposes one of the ruses used by some CNC equipment manufacturers – because stepper motors are rated by their holding (low-speed) torque, some manufacturers quote a motor torque rating on their product datasheet without publishing the drop off in torque that is accompanied by using that motor at any useful feedrate. Beware of high torque-rated stepper motors – they are high inductance motors that have considerable torque losses at higher RPMs.



Enabling Your Ideas

Technical Document

Tormach Evaluations

Test regimen

In all, we evaluated 21 drivers and almost 30 motors from a range of manufacturers. The various combinations of motor and driver resulted in over 1,000 unique tests and well over one million data points that were collected. The tests performed included:

- Positional accuracy (including linearity)
- Torque
- Noise
- Vibration
- Heating
- Reliability

When possible, these tests were performed in-situation on the machine itself. This resulted in 'real world' values that can be used to directly quantify improvements as they relate to our machines. We ran tests on machines that were both within normal spec and machines that had deliberately been put out of adjustment to evaluate the sensitivity of the test results to variations in machine setup. We tested motor/driver combinations that were coupled to a machine with over-tight gibs, loose gibs, as well as motors coupled to just a ballscrew (no table attached). We tested motors at twice their rated current, and when they failed to overheat at double the rated current we wrapped them in insulation to heat them further. We tested motors to their breaking point, and we looked at the differences in performance between motors we had abused and motors we had just taken out of the box. We tortured motors, placing 500 lbs on the mill table and another 150 lbs on the spindle and then we commanded 150 IPM moves at extreme accelerations in three axes simultaneously for hours on end. We learned many things during this process (one of which was that President's office should not share a wall with the R&D room where machines were tested non-stop under load for months).

It quickly became apparent that the three phase motors had a number of advantages over the two phase motors. With 300 natural steps per revolution, three phase motors universally displayed better positional accuracy than their 200 steps/rev two phase counterparts. Three phase motors seemed to be much less susceptible to vibration when operated at their natural resonant step frequencies. Furthermore, the resonant frequencies of the three phase motors occurred at higher feed rates which were more conducive to inertial damping. Many of the three phase motors that we tested were able to provide good low speed torque even though their inductance was lower than comparable two phase motors, meaning that their high speed performance was significantly better than that of two phase motors. Lastly, we noted that three phase motors and drivers are inherently more reliable, in that there is no way to cross the phases when wiring the motor to the driver. Crossing wires when wiring a two phase motor to a driver will destroy the driver; with a three phase motor it causes the motor to run backwards.

Test Results

Linearity and Positional Accuracy

We used a Fowler Mark IV dial indicator with a resolution of around 1 micron (.00005") to measure commanded versus actual position on a PCNC 1100 mill outfitted with a number of different stepper/driver combinations. When the driver to be tested had a trim pot available for tuning (e.g. Gecko 201) the drives were first tuned according to the manufacturer's instructions.

The machine was jogged in increments of 0.0001" – the finest resolution available on a 2 phase 10 microstep motor system. Three trials of 50 readings (corresponding to 0.005" of travel) were recorded for each motor/drive combination. Positional error tended to follow a sinusoidal pattern; full step positions were quite accurate but non-linearity was evident in between full step positions:

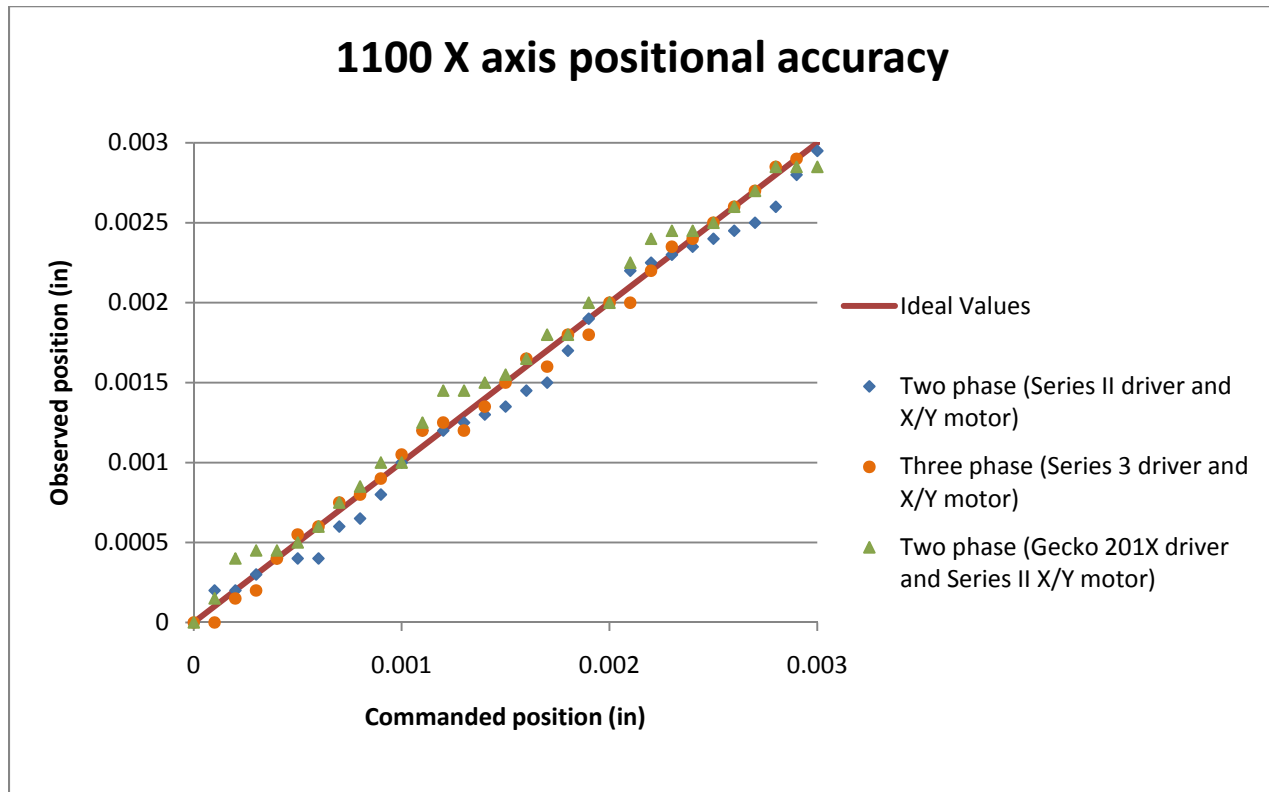

Figure 7 Positional accuracy results from three motor/driver trials

Absolute values of the positional errors were averaged and a small sample of the results is presented in Figure 8. Note the greater accuracy associated with the three phase motor/driver combinations – likely attributable to the inherently greater step resolution (1.2° for three phase motors as opposed to 1.8° for two phase motors). After differences related to motor type (two versus three phase), the driver had the second greatest influence on the results. The two phase motor/driver combinations displayed in Figure 8 used the same motor with 6 different drivers, yet the data show a wide range of positional accuracy values.

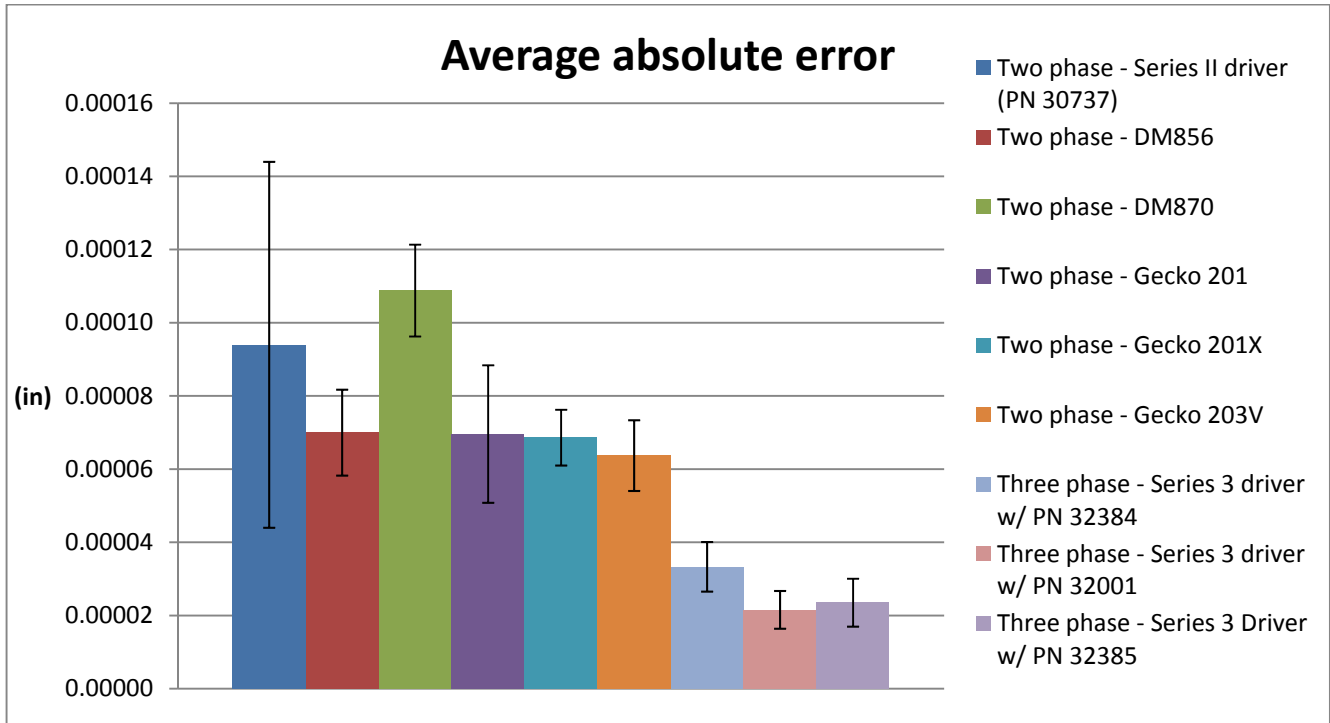

Figure 7

Torque

We used axial thrust as a proxy for measuring stepper motor torque. This thrust force was measured in-situation on a PCNC 1100 mill as the load required to stall the X axis over a range of feed rates. The stalling force, measured by a Crane digital scale, reached values as high as 1600 lbs in some conditions. An initial round of tests was conducted taking 3 measurements each at 10% increments of feed rates between 0 and 265 IPM. After narrowing down the field to a handful of prospective motors and drivers, tests were repeated with finer resolution. Three measurements for each motor/driver combination were taken every 10 IPM between 10 and 200 IPM. Abbreviated results from the initial round of testing can be seen in Figure 8:

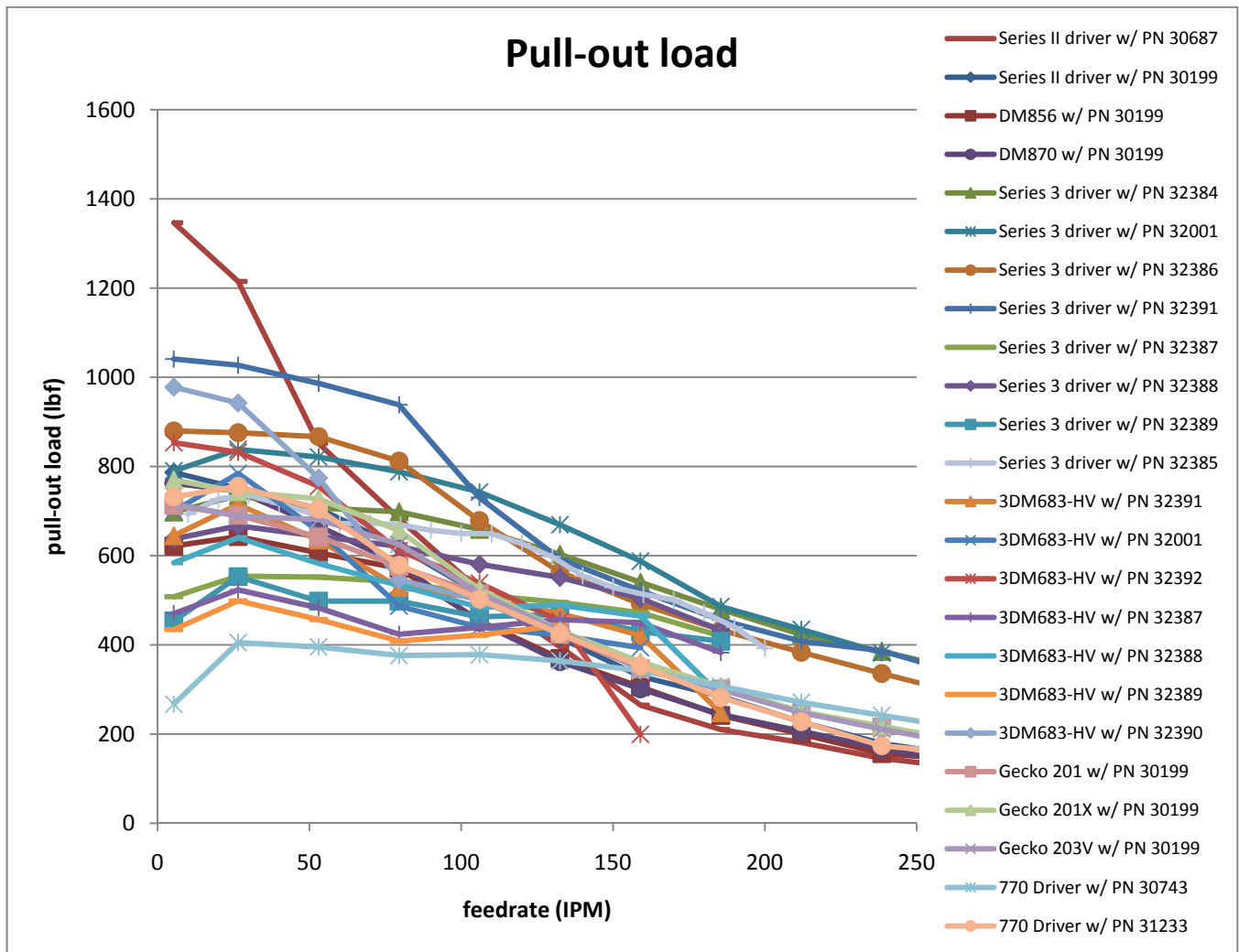

Figure 8

As mentioned previously, stepper motors tend to generate their maximum (rated) torque at low speeds. We were particularly interested in finding a motor/driver combination that gave us a flat torque/speed curve that extended into higher speed operation (feed rates above 100 IPM.) This was another area where three phase systems seemed to have an inherent advantage over two phase systems. The following chart shows the near absence of the knee in the torque/speed curve of some of the better-performing three phase motors that we tested:

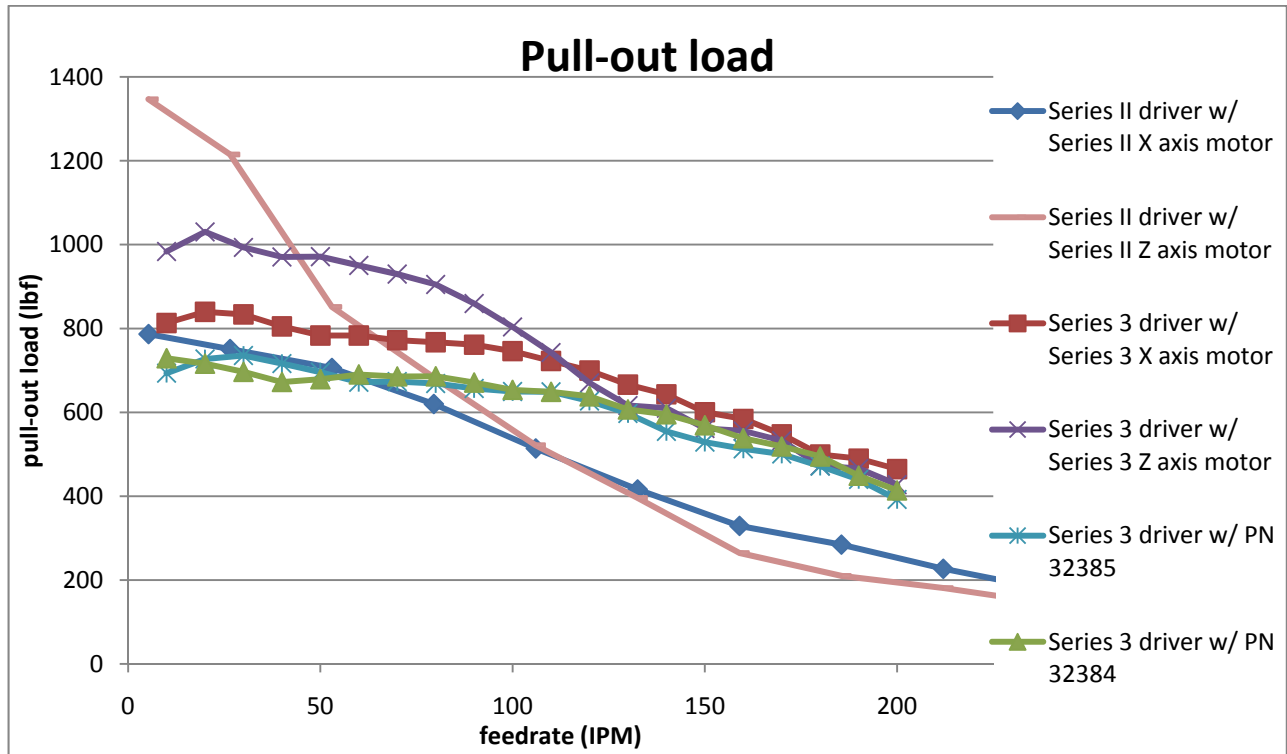

Figure 9

Noise/Vibration

Vibration testing was carried out using a digital vibration meter (CEMA VM6360), with the transducer mounted to the vertical surface at the right end of the X axis. The machine executed a G code program that moved the x axis for 10 second intervals at each integer feedrate from 1 IPM to 90 IPM. The data correlated so well with decibel readings taken with a hand help dB meter that vibration data was used as the sole source of noise measurement.

In all cases, three phase motors were significantly quieter than two phase motors. Peak vibrations readings for two phase motors, occurring at feed rates of around 10 IPM, were on average two to 4 times larger than the resonant peak on three phase motors. Throughout the range of feed rates, three phase motor noise was inaudible with the spindle on.

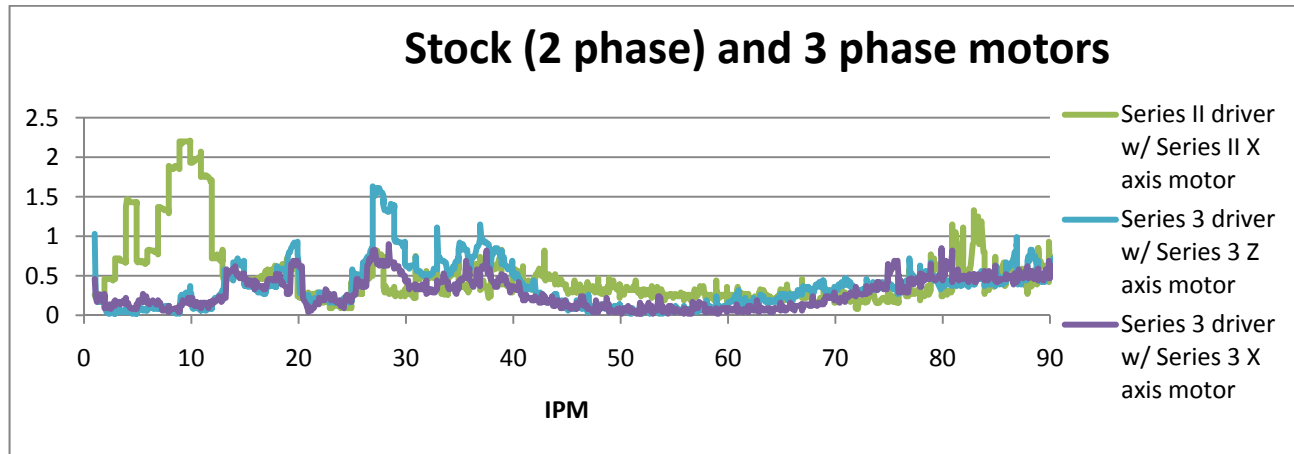

Figure 10

Reduced vibration directly translates into lower noise. The Series 3 PCNC 1100 and 770s are significantly quieter because of the change to 3 phase stepper motors. In theory, a machine with reduced vibration will produce a part with a better surface finish as well, but this was impossible to demonstrate empirically. Differences in surface finish are difficult to measure, and the effects of tooling, cutting parameters, and fixturing dwarf any influence that the motors may have.

Heating

Several components contribute to heating in stepper motors. Resistance losses (due to resistive heating in the stator windings), and iron losses (due to induced currents and hysteresis) are the main sources of stepper motor heating followed distantly by mechanical losses (friction). When the motor is stopped, only resistive loss contributes to motor heating. Iron losses contribute more and more to motor heating as the speed of operation increases due to the alternating magnetic fields in the stator that induce motion. During normal motor operation iron losses dwarf resistive losses; it has been estimated that iron losses account for ~90% of total motor loss at higher operating speeds.

Most stepper motors are rated for operation up to 200° F. In our testing we found that, while some drivers tended to heat a motor more than others, it was nearly impossible to get a motor past the range of safe operation. The stepper motors on Tormach machines are mounted to a substantial mass of cast iron that acts as a very efficient heat sink, and generally kept the motors within 130°-150° F. Nevertheless, cooler is better. The heat of a motor can add a small amount of thermal distortion to the machine and lifespan of any motor may be increased by keeping the operating temperature low. In consideration of this we took motor temperature data when used with different drivers. When possible we used the same motor for all measurements – obviously three phase drivers necessitated the use of a different motor than the two phase drivers.

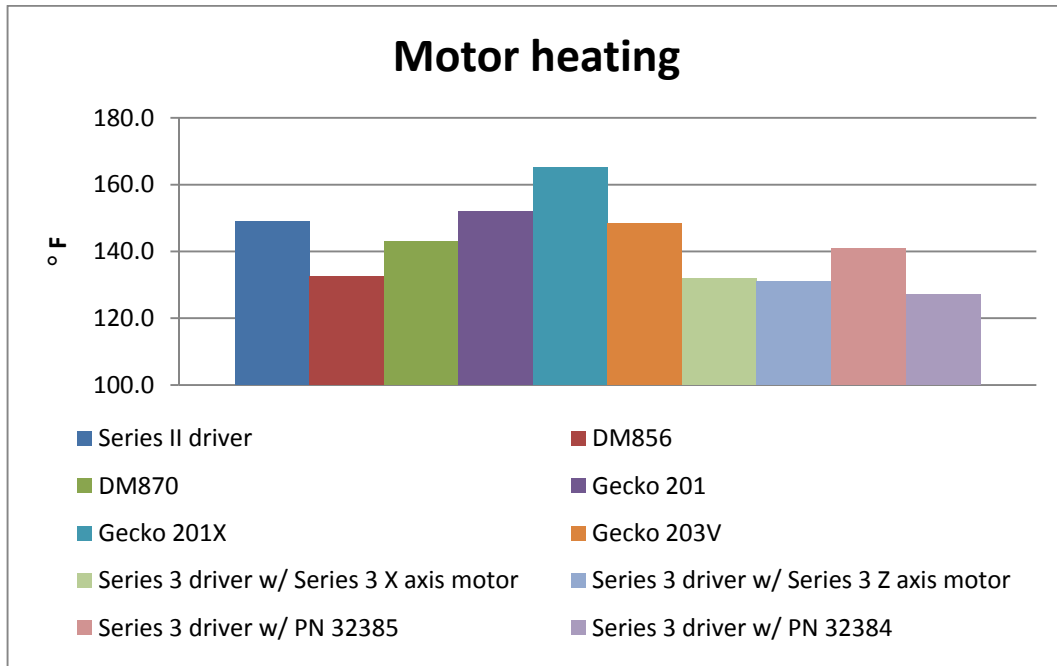

Figure 11

All readings were taken using a non-contact IR thermometer after 1 hour of continuous operation at 50 IPM. Interestingly, the motor temperature did not correlate well with motor current:

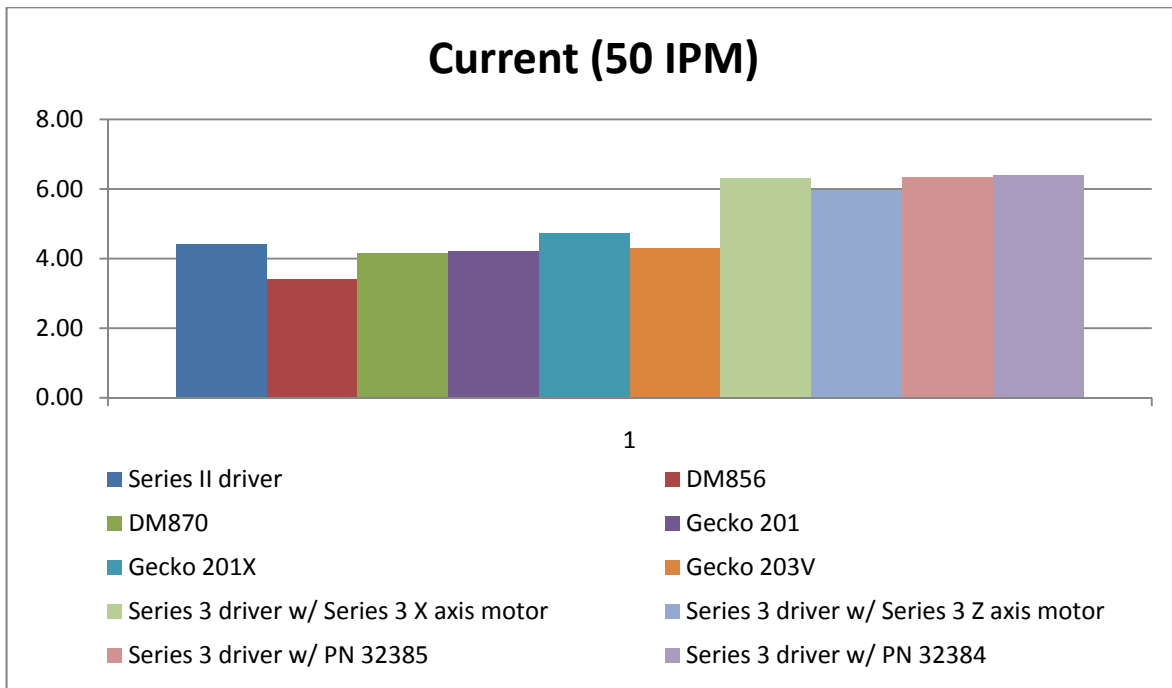

Figure 12



Enabling Your Ideas

Technical Document

The data shows that the three phase driver/motor combinations were able to maintain lower temperatures with phase currents that were consistently 1 - 2.5 A higher than the two phase driver/motor combinations. It should be noted that the phase resistance (directly related to the amount of resistive heating) of the two-phase motor was equal to that of the three phase motors tested (0.7 Ohms).

Vendor Considerations

Early in the research it became apparent that Leadshine manufactured stepper drivers with superior performance. As the axis drivers are a critical element in our machinery, we wanted to understand more about Leadshine and how they did things. In 2010 three engineers from Tormach visited the factory in Shenzhen China where we met the president as well as several managers and engineers. In the last 25 years I have walked the production floors of many servo, stepper, and VFD factories. I've seen everything in drive manufacturing, from the high end facilities of USA based Rockwell/Allen Bradley, to backroom circuit board sweatshops in China. I have never seen better facility than Leadshine. With hundreds of people working in the assembly rooms and thousands of drives in test & assembly, it was clear that we were not given a prepared "dog and pony show". Instead we were seeing how things were actually done. All workstations had top notch test equipment, with Fluke meters and Tektronix scopes everywhere. Everything was "best in class" from the anti-static procedures with wrist straps, booties in production areas, through the environmental controls in the storage area, where reels of electronic components were stored.

Our testing of the digital bipolar stepper drive initially pointed out some software errors in the drive. We worked closely with their engineers to identify the issues and became involved in developing improvements in that driver. In the final decision we didn't use that model drive, but our experience has taught us that the Leadshine engineering team is responsive, competent, and dedicated to getting it right. We think a lot alike.

Difficult Decisions

After all the data was analyzed, the two leading solutions were 1) Leadshine fully digital bipolar driver 2) Leadshine analog 3 phase driver. While 3 phase motors are naturally smoother operating than bipolar motors, the Leadshine digital bipolar drive incorporates smoothing and anti-resonance algorithms which make a bipolar drive almost vibration-free at very low speed. At speeds below 10 inches per minute it appeared to be a superior solution. The problem was that the fall-off of torque at higher speeds was far more dramatic on the digital drive than it was on an analog drive. Our machine designs intentionally limit top speed to something below the point where torque approaches the necessary levels, leaving a safety zone of surplus torque capacity. If we used the digital driver, that safety zone would be smaller than we like to see. This is important because, once the surplus torque goes to zero, the machine runs the risk of actually losing step positions. Understanding that a quiet running motor is nice, but any risk of losing positioning is a machining failure, we decided the 3 phase driver would be a superior solution.

This preference for 3 phase led us to another difficult decision. Tormach has always had a strong dedication to legacy customers. Every time we've developed a major advancement we have been able to offer a retrofit kit that would bring our earlier machines up to the latest technology. If we upgraded the new machine design to a better bipolar driver, the upgrade kit for older machines would require three new bipolar drivers, expensive but probably affordable. If we upgraded new machine design to the 3 phase technology then any upgrade kit would have to include three new



Enabling Your Ideas

Technical Document

motors as well as three new drivers. It would be a complete change out of axis motion. This would make any upgrade kit considerably more expensive. It could be difficult for customers with older machines to afford. This came down to an engineering meeting that focused on this issue. There were 8 engineers and technicians in the room, embroiled in a 2 hour debate. The turning point came when someone suggested that we simply sell the upgrade kits far below market value. It was something like "Upgrade kits aren't a profit center for us, they're just our way of taking care of loyal customers, so why don't we just sell the upgrade kit really cheap?" Perfect solution, end of meeting. The decision was to use 3 phase stepper technology in all new machines, and heavily discount a 3 phase upgrade kit to previous machine customers.

Summary

We feel the Series 3 release of the PCNC mills represents a significant step forward in the evolution of the PCNC product line. We're also happy that we can provide Series 3 axis upgrade kits for all previous machine customers, from the recent Series II machines all the way back to serial number 1 of the original PCNC 1100.

In the six years since the introduction of the PCNC 1100 mill, our machines have seen many thousands of hours in service. Some mills end up as weekend warriors in hobby shops while others are used three shifts in harsh production environments. The decision to change something that has been proven over years of reliable operation was not taken lightly, and we needed to fully explore our options before making any changes to the motors/drives of the mill. We went into this investigation feeling fairly knowledgeable about stepping motor systems, but in hindsight we had a lot to learn. Given the scope of the testing, we are confident that the Series 3 machines will not only represent an improvement over the previous models, but will deliver the best performance, reliability, and value of any machine in their class.