

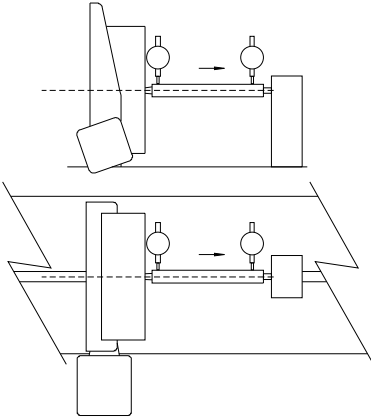
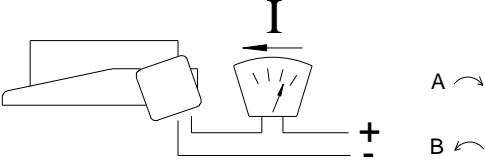

Tormach Motorized Rotary
Table
Model MRT-6

Quality
Certification

Number	Item	Test Sketch	Allowable	Actual
1	Flatness of table surface (no protrusion on table center)		0.010mm (.0004)	
2	Axial run-out of table surface		0.020mm (.0008)	
3	Parallelism between table surface and bottom surface		0.012mm (.0005)	
4	Radial run-out of tapered center bore		A) 0.015mm (.0006)	A
			B) 0.020mm (.0008)	B
5	In vertical position: A) Parallelism between spindle centerline and bottom B) Parallelism between spindle and keyway		0.010mm (.0004) on the length of 50 mm	A
				B

6	<p>In the vertical position, parallelism between table center line axis and:</p> <p>A) tailstock center axis and bottom</p> <p>B) tailstock center axis with T-slot</p>		0.020mm (.0008)	
7	<p>Minimum torque setting for rotating operation with motor.</p> <p>A) CW</p> <p>B) CCW</p>		75 TTU	

Technical Inspector

Model

Serial Number

Date
